



Speaker and Speaker- Strobes

757 Series



Overview

Integrity Speakers and Speaker-Strobes are designed for broadcasting high quality, integrated, emergency voice communications, as well as alert and alarm tone signals. Use them in life safety applications, especially to notify the hearing impaired and where transitory people are expected such as in hotels, malls, airports, hospitals and other public buildings.

These speakers are shipped complete with a 'DC Blocking Capacitor' to permit electrical supervision of the audio distribution circuit. Models for 25 Vrms and 70 Vrms circuits are available. The mylar speaker with sealed back construction provides extra durability and improved audibility. Wattage taps from 1/4W to 2W provide maximum on-site flexibility.

Integrity's rugged plastic housing is available with a red or white textured finish. With its ingenious mounting sub-plate, Integrity is firmly held in place with a single screw ensuring a quick, attractive installation. A separate trim plate is not required for flush mounting.

The flash from Edwards strobes will be noticed from almost any position in the room, corridor, or large open space. Edwards strobes are UL1971 listed with both wall and ceiling cd intensity ratings (see Specifications). This is useful in areas where the Authority Having Jurisdiction (AHJ) permits ceiling mount strobes.

Standard Features

- UL 1971-listed synchronizing strobe**
 Integrity strobes synchronize to the latest UL 1971 requirements when used with a synchronization source.
- Genesis-compatible**
 All Genesis and Integrity strobes on the same circuit meet UL 1971 synchronization requirements when used with an external control module.
- Approved for public and private mode applications**
 UL 1971-listed as signaling devices for the hearing impaired and UL 1638-listed as protective visual signaling appliances.
- High dBA Output**
 High efficiency, sealed mylar speaker cone produces a loud 90 dBA at 2 watts.
- Multiple Output Taps, 25 or 70 Volt Models**
 Easy to select for 1/4, 1/2, 1, or 2 watt operation. Integrity speakers are supplied with a DC Blocking Capacitor for audio circuit supervision.
- Field changeable field markings**
 Lens language or standard "FIRE" marking is easily changed with optional LKW and LKC series lens kits.
- Easy Installation**
 Flush mount to standard North American 4" square box with 1 1/2" extension ring (USA only). Integrity's universal mounting plate allows it to be wired and then left hanging free for easy inspection and testing before it is fastened to the electrical box.

Application

NOTE: The installation of visible and audible signals are subject to national and local standards, codes, and ordinances. Consult your Authority Having Jurisdiction for device installation requirements, application standards, and minimum performance specifications.

Speakers

All Integrity speakers include a DC blocking capacitor to allow electrical supervision of the audio distribution circuit. Models for 25 V_{RMS} and 70 V_{RMS} circuits are available. The mylar speaker with its sealed back construction provides extra durability and improved audibility. Wattage taps from 2 W to 15 W provide on-site flexibility.

The suggested sound pressure level for each signaling zone used with alert or alarm signals is a minimum of 15 dB above the average ambient sound level or 5 dB above the maximum sound level having a duration of at least 60 seconds, whichever is greater. This is measured 5 feet (1.5 m) above the floor. The average ambient sound level is the RMS, A-weighted sound pressure measured over a 24-hour period.

Doubling the distance from the signal to the ear will theoretically cause a 6dB reduction in the received sound pressure level. The actual effect depends on the acoustic properties of materials in the space. Doubling the power output of a device (e.g.: a speaker from 1W to 2W) will increase the sound pressure level by 3dBA. A 3dBA difference represents a barely noticeable change in volume.

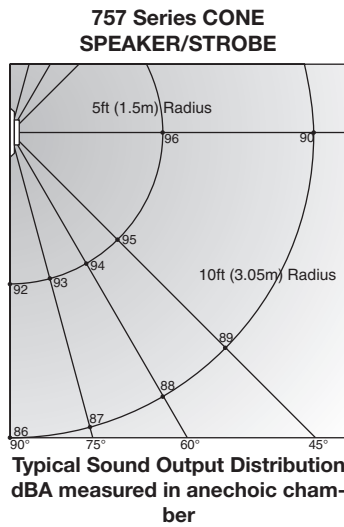

Strobes

Edwards strobes are UL 1971-listed for use indoors as wall-mounted or ceiling-mounted public-mode notification appliances for the hearing impaired. Prevailing codes require strobes to be used where ambient noise conditions exceed specified levels, where occupants use hearing protection, and in areas of public accommodation. Consult with your Authority Having Jurisdiction for details.

As part of the Enhanced Integrity line of products, 757 Series strobes exceed UL synchronization requirements (within 10 milliseconds other over a two-hour period) when used with a synchronization source. Synchronization is important in order to avoid epileptic sensitivity.

Integrity strobes are fully compatible with Edwards Genesis signals.

NOTE: The flash intensity of some visible signals may not be adequate to alert or waken occupants in the protected area. Research indicates that the intensity of strobe needed to awaken 90% of sleeping persons is approximately 100 cd. Edwards recommends that strobes in sleeping rooms be rated at at least 110 cd.

WARNING: These devices will not operate without electrical power. As fires frequently cause power interruptions, further safeguards such as backup power supplies may be required.

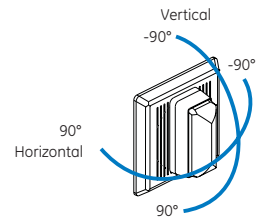

Light Distribution Patterns

UL 1971 WALL MOUNTED STROBE LIGHT OUTPUT

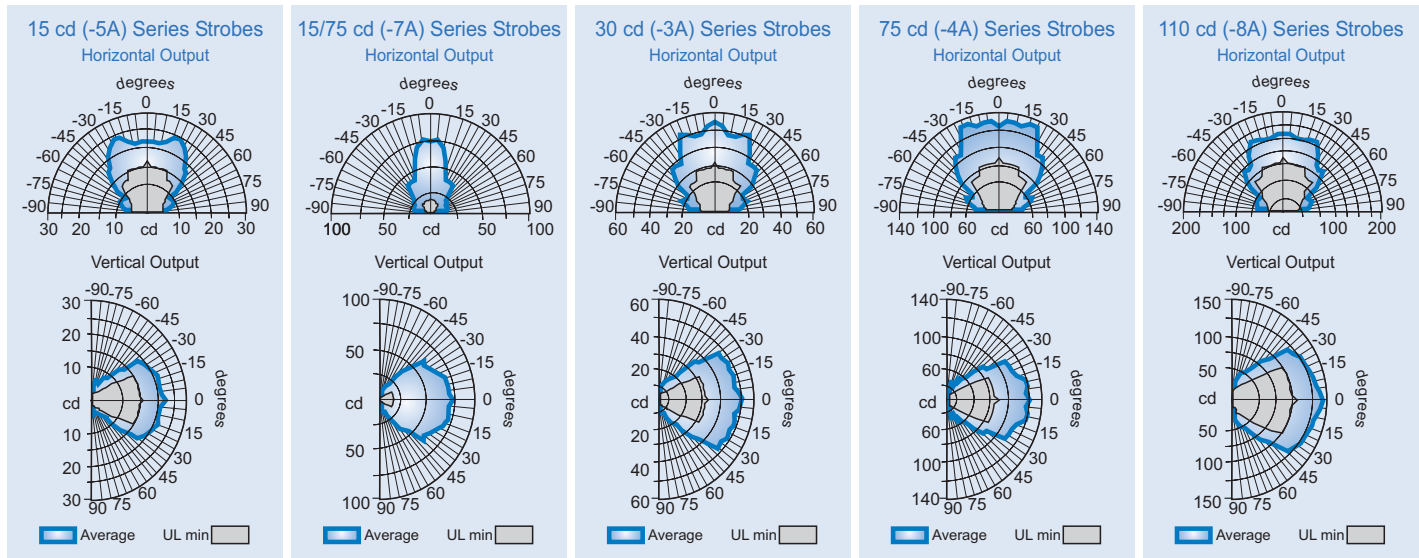

Installation and Mounting

All models fit to a standard flush mounted, North-American four inch square electrical box, 1-1/2 inch (38 mm) deep with 1-1/2 inch (38mm) extension ring. CAUTION (Canada): When using Iberville (Commander extension rings, 2-1/8 inch (54mm) deep extension ring is required. Optional flush trims are not required. For surface mount, use EST's custom indoor and outdoor boxes painted in color-matched red or white epoxy. Edwards recommends that these fire alarm speaker/strobes always be installed in accordance with the latest recognized edition of national and local fire alarm codes.

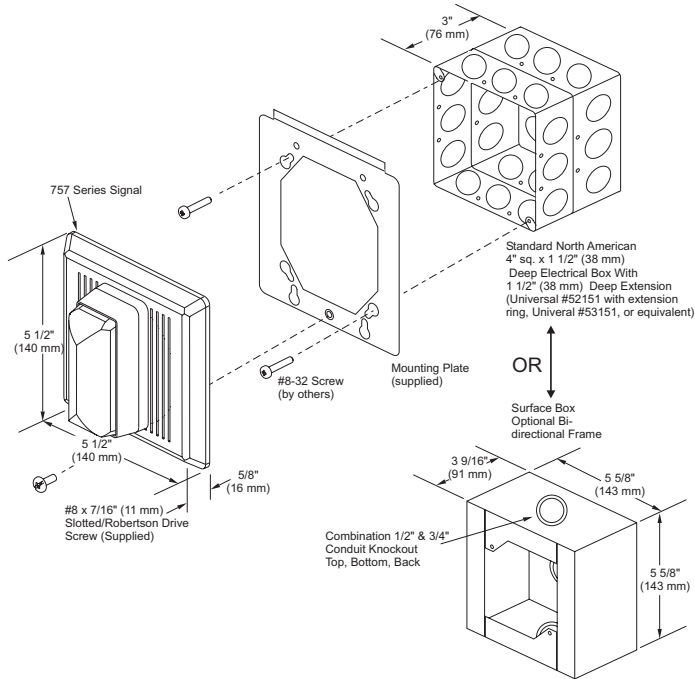

Typical Wiring

The strobe must be connected to signal circuits which output a constant (not pulsed) 16 to 33 Vdc voltage. Depending on the model, the speaker must be connected to either 25 or 70 V audio circuits.

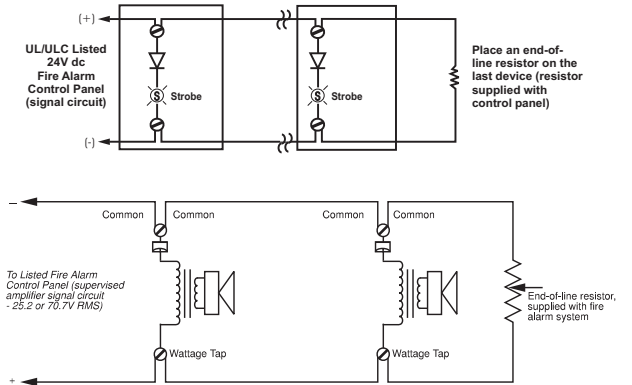

Operating Current (RMS)

UL Rating	15 cd	15/75 cd	30 cd	75 cd	110 cd
16 Vdc	109	150	130	263	329
16 Vfwr	150	210	189	333	420

Typical Current	15 cd	15/75 cd	30 cd	75 cd	110 cd
24 Vdc	69	90	89	159	180
24 Vfwr	108	128	134	255	260

Vdc: Volts direct current, regulated and filtered
 Vfwr: Volts full wave rectified

Current Draw Notes and Comments

1. Current values are shown in mA.
2. UL Nameplate Rating can vary from Typical Current due to measurement methods and instruments used.
3. Edwards recommends using the Typical Current for system design including NAC and Power Supply loading and voltage drop calculations.
4. Use the 16 Vdc RMS current ratings for filtered power supply and battery AH calculations. Use the 16 Vfwr RMS current ratings for unfiltered power supply calculations.
5. Fuses, circuit breakers and other overcurrent protection devices are typically rated for current in RMS values. Most of these devices operate based upon the heating affect of the current flowing through the device. The RMS current determines the heating affect and therefore, the trip and hold threshold for those devices.

Sound Level Output

Wattage	Speaker		Speaker-strobe	
	UL1480	Average	UL 1480	Average
¼ W	81.0	81.0	78.0	78.0
½ W	84.0	84.0	81.0	81.0
1 W	87.0	87.0	84.0	84.0
2 W (UL)	90.0	90.0	87.0	87.0

Sound level output notes

- All values shown are dBA measured at 10 feet (3.01m).
- UL1480 values measured in reverberation room.
- Average values are measured in anechoic chamber.

Specifications

Rated Strobe Output - candela (cd)	757-5A-SS	757-7A-SS	757-3A-SS	757-4A-SS	757-8A-SS
UL 1638 & ULC S526	15 cd	15/75 cd	30 cd	75 cd	110 cd
UL 1971	15 cd (wall mount only)	15 cd wall 15 cd ceiling	30 cd wall 15 cd ceiling	75 cd wall 60 cd ceiling	110 cd wall 60 cd ceiling
Input/Operating Volts	Speaker: 25 VRMS (suffix "-S25") or 70 VRMS (suffix "-S70") - see ordering table Strobe: 16-33 Vdc Continuous				
Speaker Cone	Speaker frequency response 250 to 13,000 Hz; 4" (102 mm) mylar cone, sealed back construction, rated at 8 watts, 8 ohm voice coil				
Strobe Flash Rate	Synchronized at one flash per second. External control module necessary to meet UL 1971 synchronization requirements of 10 milliseconds over a two-hour period.				
Synchronization Sources	G1M-RM, SIGA-CC1S, SIGA-MCC1S, BPS6, BPS10				
Flash Tube Enclosure	Clear LEXAN				
Lens Markings	Supplied with LKW-1 "FIRE" red letters, vertical both sides (Wall Mount) - see LKW and LKC series for ceiling style and optional markings				
INDOOR Operating Environment	85% @ 30° C relative humidity; 32-120° F (0-49° C) ambient temperature				
Wire Connections	Terminals - separate, polarized inputs for Speaker & Strobe, #12 AWG (2.5 mm ²) max.				
Housing*	Textured, color impregnated engineered plastics - exceeds 94V-0 UL flammability rating				
Mounting - INDOOR	Flush: North-American 4" square box, 1-1/2" (38 mm) dp with 1-1/2" (38 mm) ext. ring. CAUTION (Canada): When using Iberville (Commander) extension rings, 2-1/8" (54 mm) deep extension ring is required. Surface: 757A-SB* Backbox Bi-directional: 757A-BDF* Mounting Frame				
Agency Listings	UL 1971, UL 1638, UL 1480, ULC S526, ULC S541, MEA, CSFM, FM (All models ADA Code compliant - Federal Regulation Chapter 28 Part 36 Final Rule)				

Ordering Information

Catalog Number	Description	Ship Wt. lb. (kg)
25 Volt Speakers		
757-1A-S25	Speaker, Red	2.5 (1.2)
757-1A-S25W	Speaker, White	
25 Volt Speaker/Strobes		
757-5A-SS25	Speaker-Strobe, 15cd, Red	2.7 (1.3)
757-5A-SS25W	Speaker-Strobe, 15cd, White	
757-7A-SS25	Speaker-Strobe, 15/75cd, Red	
757-7A-SS25W	Speaker-Strobe, 15/75cd, White	
757-3A-SS25	Speaker-Strobe, 30cd, Red	
757-3A-SS25W	Speaker-Strobe, 30cd, White	
757-4A-SS25	Speaker-Strobe, 75cd, Red	
757-4A-SS25W	Speaker-Strobe, 75cd, White	
757-8A-SS25	Speaker-Strobe, 110cd, Red	
757-8A-SS25W	Speaker-Strobe, 110cd, White	
70 Volt Speakers		
757-1A-S70	Speaker, Red	2.5 (1.2)
757-1A-S70W	Speaker, White	
70 Volt Speaker/Strobes		
757-5A-SS70	Speaker-Strobe, 15cd, Red	2.2 (1)
757-5A-SS70W	Speaker-Strobe, 15cd, White	
757-7A-SS70	Speaker-Strobe, 15/75cd, Red	
757-7A-SS70W	Speaker-Strobe, 15/75cd, White	
757-3A-SS70	Speaker-Strobe, 30cd, Red	
757-3A-SS70W	Speaker-Strobe, 30cd, White	
757-4A-SS70	Speaker-Strobe, 75cd, Red	
757-4A-SS70W	Speaker-Strobe, 75cd, White	
757-8A-SS70	Speaker-Strobe, 110cd, Red	
757-8A-SS70W	Speaker-Strobe, 110cd, White	

Synchronization Sources		
G1M-RM	Genesis Signal Master Remote Mount (1-gang)	0.2 (0.1)
SIGA-CC1S	Synchronization Output Module (Standard Mount) - UL/ULC Listed	0.5 (0.23)
SIGA-MCC1S	Synchronization Output Module (UIO Mount) - UL Listed	0.18 (0.08)
BPS6A	6.5 Amp Booster Power Supply	13 (5.9)
BPS10A	10 Amp Booster Power Supply	13 (5.9)
Mounting Accessories		
960A-4SF	Flush Box, Indoor	1.5 (.7)
757A-SB	Surface Box, Red, Indoor	
757A-SBW	Surface Box, White, Indoor	
757A-BDF	Bi-directional Mounting Frame, Red	4 (1.8)
757A-BDFW	Bi-directional Mounting Frame, White	
Lens Marking Kits*		
LKW-1	"FIRE", Wall Orientation (supplied)	0.2 (.1)
LKW-2	"FEU", Wall Orientation	
LKW-3	"FIRE/FEU", Wall Orientation	
LKW-4	"SMOKE", Wall Orientation	
LKW-5	"HALON", Wall Orientation	
LKW-6	"CO2", Wall Orientation	
LKW-7	"EMERGENCY", Wall Orientation	
LKW-8	"ALARM", Wall Orientation	
LKW-9	"FUEGO", Wall Orientation	

*Change "W" to "C" for Ceiling Mount (e.g. LKC-1)



Contact us...

Email: edwards.fire@fs.utc.com

Web: www.est-fire.com

EST is an **EDWARDS** brand.

1016 Corporate Park Drive
Mebane, NC 27302

In Canada, contact Chubb Edwards...

Email: inquiries@chubbedwards.com

Web: www.chubbedwards.com

© 2013 UTC Fire & Security Americas Corporation, Inc. All rights reserved. Specifications subject to change without notice. Edwards is part of UTC Climate, Controls & Security, a unit of United Technologies Corporation.
